

UNITED®

Instructions Manual Safe Box

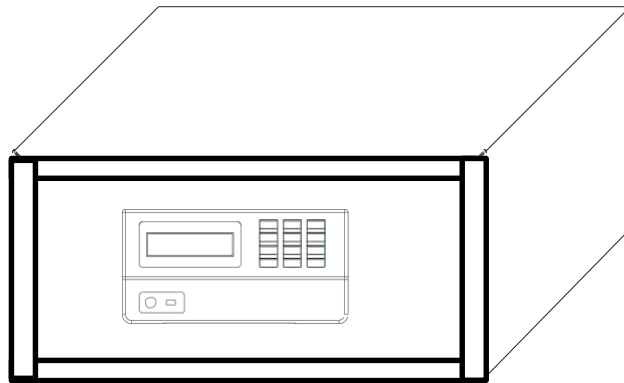

Model: SFH-1185

Thank you very much for using this product!
Before using this product, please read this user
manual to ensure that you gain the maximum benefit
from it!

Install Your Safe

Please install the safe before use it, the position of installation holes are located at the bottom and the back of the safe.

1. Cement Material: Drill holes on the surface according to the mounting holes of the safe, insert the expansion sleeve into the mounting hole, fix the safe with expansion bolts.

2. Wooden Material: Drill holes on the surface according to the mounting holes of the safe, and fix the safe with the self-tapping screw.

When the installation is completed, please install the battery and change the password at once.

Don't put the emergency key into the safe.

Operation Instructions

I. Install Battery and Initialization (AA Alkaline dry Battery is suggested)

1. Please open the cover of the emergency lock during first use.

2. Open the safe with the emergency key.

3. Install 4 pieces of AA size (1.5V) batteries to the battery compartment which is on the back of the door. "Hello" will be displayed on the LCD display, the safe will go into standby mode.

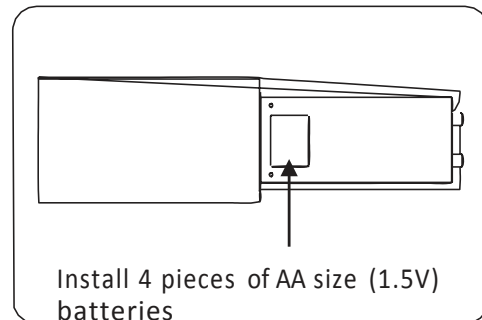
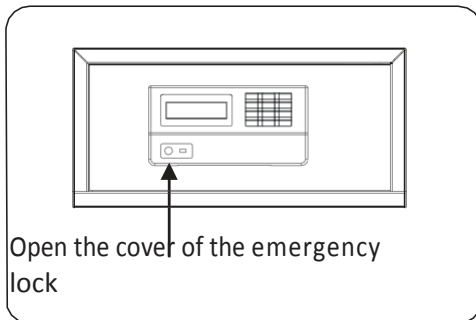

II. Open & Lock the Safe

Opening the safe

1. Using the guest password: Enter a 3-6 digit code and press "#" to confirm. The LCD display will show "OPEN" and the door will be opened automatically. The factory set password for the end user is 123. (If you want to hide the password, you can press "#" button before entering the password so that the LCD display will show "-" instead of the password)

2. Using the administrator password: Double press "*", the LCD will display "SUPER". Press "000000", and then "#". The LCD will display "CC ---". Press "00" and "#", the LCD will display "OPENED" and the door will be opened automatically.

3. Using the emergency key: Open the lock cover and insert the key. The door will open.

Locking the Safe

Enter your 3-6 digits personal password while the door is closed. Press "#" to confirm the password and "CLOSE" will be displayed on the LCD (The user can lock the safe by pressing "#" directly without changing the password within 5 minutes after opening it).

Remark: "ERROR" will be displayed if the lock -bolt is jammed. Please open the door again to make certain that the door is closed normally.

Changing the Password

1.Changing the end user's password. By inserting the new 3-6 digit code and "#" while the safe is opened, the safe will be locked.

2.Changing the hotel management password. This needs to be operated while the safe is locked. Double press " * ", the LCD will display "SUPER". Insert the hotel management password (the factory set password for hotel is "000000"), the LCD will display "CC —". Press "01" and "#", the LCD will display "NEU". Insert the new 6 digit code as the password, then press "#" to confirm and the LCD will display "REPEAT". Insert again the new password and "#" to confirm, the LCD will display "GOOD".

Normal Troubleshooting

Problem 1: Forgotten Administrator Password

Resolution:

- 1) Open the safe and remove the three screws on the back of the door.
- 2) Remove the door cover and press the black button for 5 seconds.
- 3) The LCD will display "RESET", the administration code will be changed into the initial administrator password "000000".
- 4) Close the door cover and tighten the screws and change the administrator password.

Problem 2: There is no display on the LCD

Reason: Maybe there is not enough power of the battery

Resolution: Change the battery with new one.

Problem 3: Cannot Change the Administrator or Guest Password

Reason: The lock-bolt does not come in contact with the limit switch

Resolution: Open the back door cover and fix the position of the limit switch.

Reason: The limit switch cannot operate or the connecting wire is broken.

Resolution: Open the back door cover and change the limit switch or connect the wire.

Problem 4: The Lock-bolt will rebound automatically when closing the safe

Reason: The door is not totally closed.

Resolution: Insert the password and close the door again.

Reason: The lock-bolt cannot make contact with the limit switch

Resolution: Open the back door cover and fix the position of the limit switch

Reason: The limit switch cannot operate or the connecting wire is broken

Resolution: Open the back door cover and change the limit switch or connect the wire

Problem 5: Cannot Close the Door if the door is imbalanced

Resolution: Use a 6mm Allen Key to remove the screws of the hinge.

Adjust the position of the safe door and tighten the screws.

Care and Maintenance

1. Use AA size (1.5V) batteries;
2. Please remove the batteries if the safe is not to be used for a long time;
3. The administrator password and the emergency key should be kept and used by the administrator only.
4. Please do not take apart the safe if any malfunction occurs. Contact the after-sales service department for advice.
5. Any technical data and performance improvement will not be further advised. If any question, please contact with the after sales department.

Tips

Each box comes equipped with four feet. You can install them according to your own needs, shown as below.

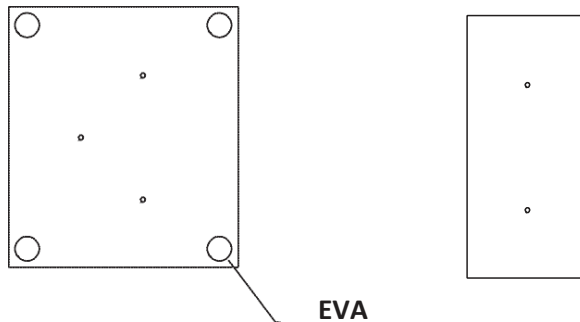

EVA