

COUNTER BALANCED SERIES

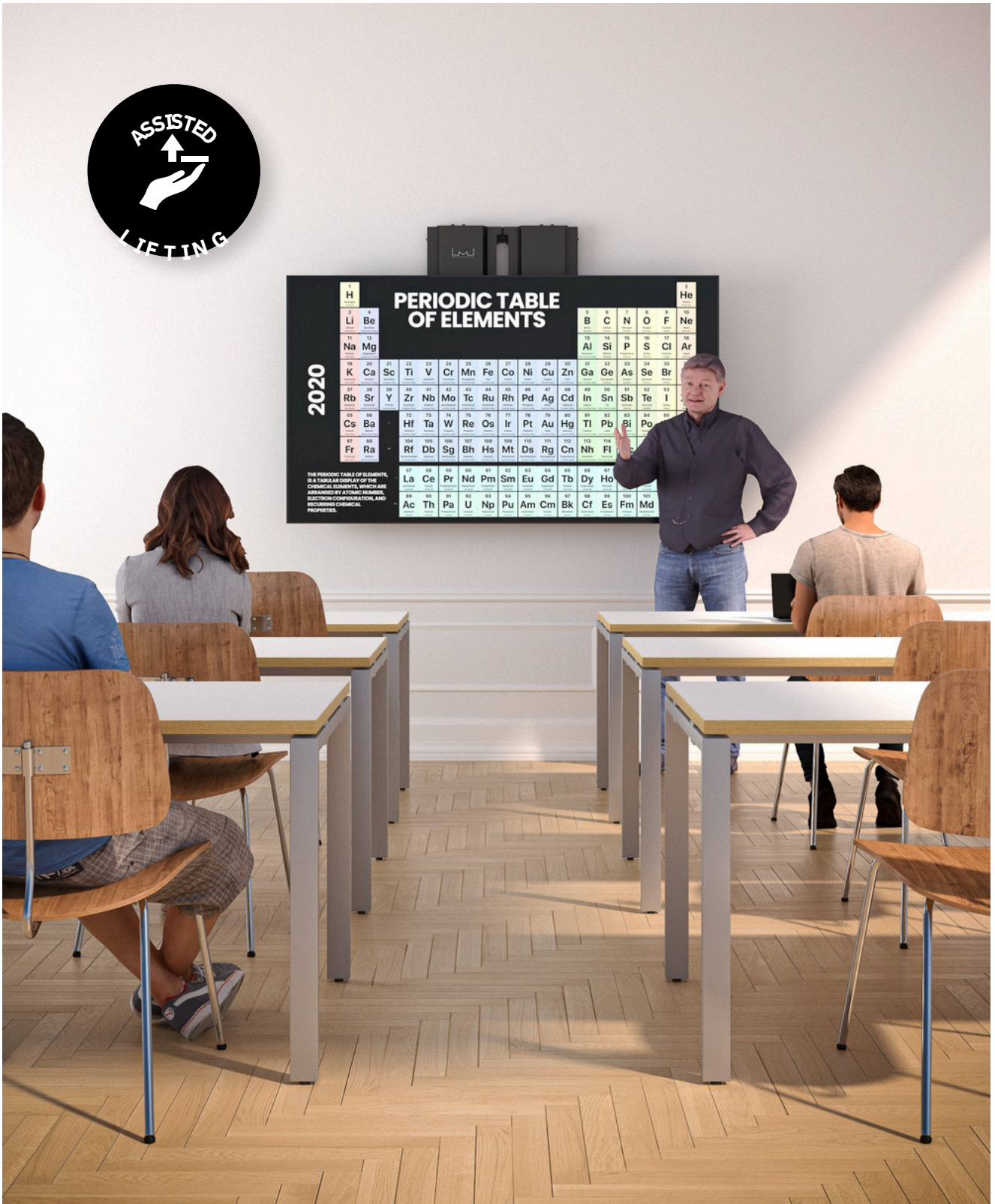

M Counterbalanced

Wall / Wall-to-Floor Mount / Floor Stand

Suitable for public spaces and ideal for meeting rooms and educational environments.

**Supports Touchscreens
from Most Manufacturers:**

Samsung, LG, Philips, DELL,
HP, Hisense, Sharp/NEC,
and more.

Weight Adjustment

Quick and easy adjustment to
set the screen's weight.

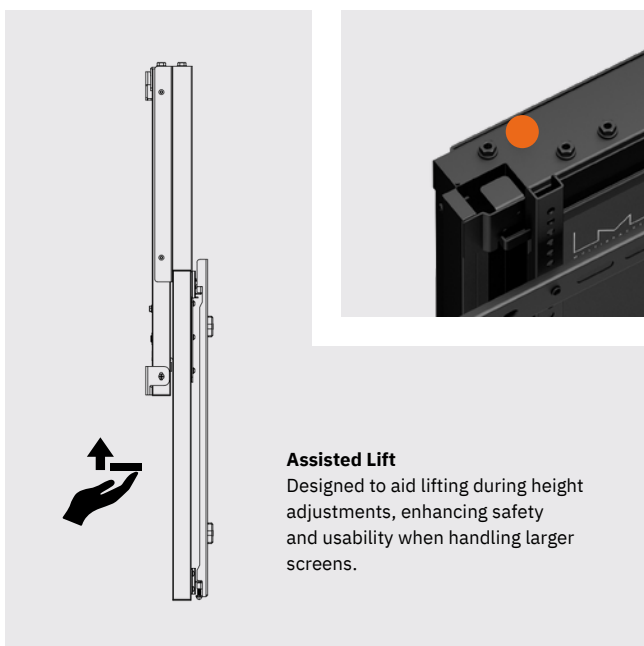

Assisted Lift

Designed to aid lifting during height
adjustments, enhancing safety
and usability when handling larger
screens.



Design with powerful and precise lifting power

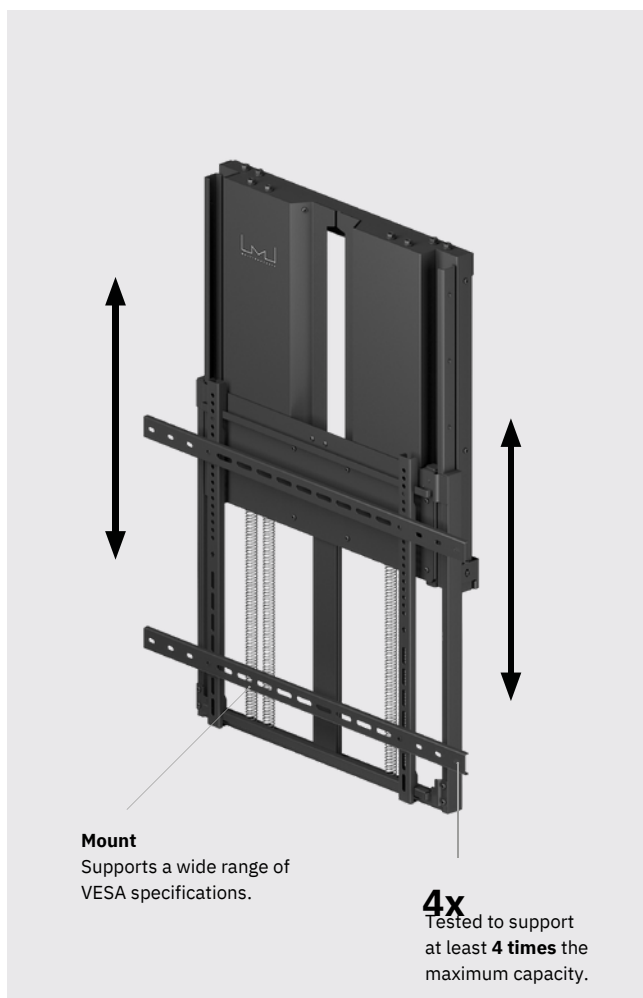

Mount

Supports a wide range of
VESA specifications.

4x
Tested to support
at least **4 times** the
maximum capacity.

Wall Mounting

With an integrated wall mount, the counter-balanced system can be installed directly on the wall, making the mount virtually "invisible" behind the screen. This enables a smooth and discreet installation, allowing the screen to be used just like a traditional whiteboard in classrooms or training rooms.

Raising and lowering a large screen or touchscreen has never been easier. With easy adjustability and a stable design, this solution is ideal for modern educational and conference environments.

Discreet design

The mount is completely hidden behind the screen, creating a sleek and clean aesthetic.

Ergonomic Height Adjustment

Allows easy customization of the screen's height to accommodate various users' needs.

Designed for Public Environments

Ideal for classrooms, conference rooms, and other educational settings, ensuring both functionality and style.



VESA:	200x200, 300x200, 300x300, 400x200, 400x300, 400x400, 600x400, 700x400, 800x500, 800x400, 800x600mm.
Max VESA:	1000x600mm (accessorie)
Colour:	Black
Height adjust.:	400 mm (manual)
Size:	127x840x660mm
Cer tification:	CE
Warranty:	5 years



15 - 40kg 35 - 65kg 60 - 90kg

Screen size:	37" - 65"	55" - 86"	75" - 90"
EAN:	735010521 0228	735007373 7765	735007373 7772
Max. load:	15 ~ 40 kg	35 ~ 65 kg	60 ~ 90kg
Max. VESA:	600x600	600x600	800x600

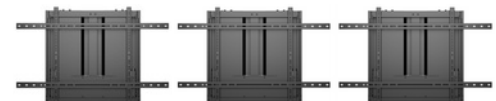

15 - 40kg 35 - 65kg 60 - 90kg

Screen size:	37" - 65"	55" - 75"	75" - 90"
EAN:	735010521 8743	735010521 8750	735010521 8767
Max. load:	15 ~ 40 kg	35 ~ 65 kg	60 ~ 90kg
Max. VESA:	1000x600	1000x600	1000x600

Wall to Floor Mount

This floor-to-wall mount provides a smart solution for distributing the weight of both the screen and the mount directly to the floor. This means the wall's load-bearing capacity doesn't have to be the only factor during installation, making the mounting process easier and safer in many environments.

With this mount, adjusting large screens or touchscreens up and down becomes seamless, enhancing both usability and ergonomics.

Stable Construction

Creates a center of gravity toward the floor, reducing the load on the wall.

Flexible Usage

Passar utmärkt i offentliga miljöer som skolor, konferensrum och mötesrum.

User-Friendly

Perfect for touchscreens and large displays where height adjustment is required.



VESA: 200x200, 300x200, 300x300, 400x200, 400x300, 400x400, 600x400, 700x400, 800x500, 800x400, 800x600mm.

Max VESA: 1000x600mm (accessorie)

Colour: Black

Height adjust.: 400 mm (manual)

Size: 127x840x660mm

Cer tification: CE

Accessorie: 735010521 0617

Warranty: 5 years



15 - 40kg

35 - 65kg

60 - 90kg

Screen size: 37" - 65"

55" - 86"

75" - 90"

EAN: 735002273 8836

735002273 8843

735002273 8850

Maxvikt: 15 - 40 kg

35 - 65 kg

60 - 90kg

VESA: 600x600

600x600

800x600

Floor Stand

Do you want a flexible solution that makes it easy to roll your counterbalanced screen between different rooms?

With this floor stand, you can easily move even the largest screens and lock them in place overnight or use them in different areas of the same room.

The stand is equipped with quality wheels, making it stable, secure, and easy to maneuver. Adjusting the height of a large screen or touchscreen has never been easier.

Mobility

Perfect for moving screens between rooms or temporarily storing them.

Robust construction

Can handle large screens while maintaining stability.

Designed for Public Environments

Ideal for meeting rooms, schools, and other educational or professional settings.



VESA: 200x200, 300x200, 300x300, 400x200, 400x300, 400x400, 600x400, 700x400, 800x500, 800x400, 800x600mm.

Max VESA: 1000x600mm (accessorie)

Colour: Black

Height adjust.: 400 mm (manual)

Size: 1080x750x1910 mm

Cer tification: CE

Warranty: 5 years



15 - 40kg



35 - 65kg



60 - 90kg

Screen size: 37" - 65"

EAN: 735010521 1447

Max. load: 15 - 40 kg

Max. VESA: 600x600

Screen size: 55" - 86"

EAN: 735007373 7741

Max. load: 35 - 65 kg

Max. VESA: 600x600

Screen size: 55" - 110"

EAN: 735007373 7758

Max. load: 60 - 90kg

Max. VESA: 800x600



15 - 40kg



35 - 65kg



60 - 90kg

Screen size: 37" - 65"

EAN: 735010521 8729

Max. load: 15 - 40kg

Max. VESA: 1000x600

Screen size: 55" - 86"

EAN: 735010521 7326

Max. load: 35 - 65 kg

Max. VESA: 1000x600

Screen size: 55" - 110"

EAN: 735010521 7333

Max. load: 60 - 90kg

Max. VESA: 1000x600

Accessories

Do you need to customize or expand the functionality of your counterbalanced solution?

With our accessories, you can easily extend and modify the product as your needs evolve. This gives you maximum flexibility and ensures that your investment can grow over time.



	Extenderkit VESA 600-1000	M Counterbalanced Floorstand	M Counterbalanced Floor to Wall Support
Screen size:	50" - 90"	55" - 110"	75" - 90"
EAN:	735010521 0617	735010521 4233	735007373 8205
Mounting holes (VESA):	1000x600mm	1040x900mm -	-
Height adjust.:	-	90 kg 55 kg	1000-2000mm
Max. load:	90 kg		125 kg
Weight:	1.88 kg		10 kg



Multibrackets® - A sustainable product choice

Our products are made of recyclable materials with sustainability in mind.

A sustainable product choice designed for durability and environmental responsibility.

EAN	Product name	Steel	Aluminum	ABS	PA	Rubber
735010521 0617	M Counterbalanced Extenderkit VESA 600-1000	1700	0	0	0	0
735010521 0228	M Counterbalanced Wallmount 15-40kg	24500	670	45	21	0
735002273 8836	M Counterbalanced Floormount 15-40kg	35200	670	45	47	100
735010521 4233	M Counterbalanced Floorstand	21370	17370	2170	332	240
735007373 7741	M Counterbalanced Floorstand 35-65kg	71870	18720	2230	393	240
735007373 7758	M Counterbalanced Floorstand HD 60-90kg	109370	19390	2275	438	340
735010521 8750	M Counterbalanced Wallmount 35-65kg VESA 1000x600	24600	680	15	42	0
735010521 8767	M Counterbalanced Wallmount 60-90kg VESA 1000x600	27700	670	45	19	0
735007373 7765	M Counterbalanced Wallmount 35-65kg	25000	670	45	21	0
735002273 8843	M Counterbalanced Floormount 35-65kg	35700	670	45	47	100
735007373 7772	M Counterbalanced Wallmount HD 60-90kg	26800	670	45	19	0
735002273 8850	M Counterbalanced Floormount HD 60-90kg	37500	670	45	45	100
735007373 8205	M Counterbalanced Floor to Wall Support	10700	0	0	26	100

The data in the table represent the weight in grams.



We reserve ourselves for printing errors Printing errors. While we strive to display all our information as correct as possible, there sometimes occurs misprinting's and faulty information in catalogues. If this happens, and it should affect in any way the forms of, for example faulty product information, or the alike, we will inform you as soon as we notice, and amend it. Please note that we reserve ourselves the right to cancel any order that has been sold presented with a misprinted information. Editing, deleting, or modification of this catalogue: We reserve the right, for any reason, to edit this catalogue. That means, without advance notice, we may suspend, discontinue, edit, or delete current information, products, services, or any other content appearing in this catalogue.

Again, Welcome to Multibrackets Europe, one of the leading manufacturers of Audio Visual Equipment in Europe.

All rights reserved, Multibrackets®, Stockholm, Sweden, 2025 / 2026



Official Distributor

MAJAR Group of Companies – Matzaridis Bros S.A.

I. Tsalouchidi 16 - 20, Business Center, 54248, Thessaloniki, Greece

Tel.: +30 2310 928 851



Multibrackets Europe AB

Phone: +46(0)8- 615 04 00 Mail: support@multibrackets.com

Postal address: Sveavägen 140 BV, SE-113 50 Stockholm, Sweden

